

« Stil und Qualität für
vielseitigen Einsatz »

DITIE
CONCEPT

D.T.E. CONCEPT GmbH
Telefon +41 61 811 80 08

Gartenstrasse 115a
Fax +41 61 811 80 09

CH-4132 MuttENZ / BL
office@dte-concept.ch

Sitzkultur Stühle Chairs TRENDSTYLE COLLECTION



Konzeption Planung Realisation Montage
Büroeinrichtung www.dte-concept.ch
Archiv Lager Logistik Automatic-Systems

TREND
STYLE
COLLECTION



NICE
&
EASY

m 210/211



Cooler Auftritt. Smarte Technik.





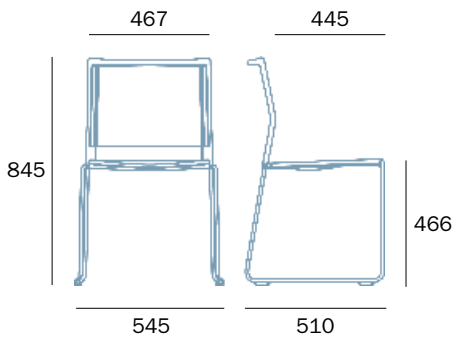

m 210/211. Das junge Stuhlprogramm mit frechem Kufengestell. Optional mit Armlehnen sowie Sitz- und Rückenpolster. Die Rückenlehne gibt es wahlweise im geschlossenen Look oder mit trendiger Netzbespannung. Unauffällige Fußgleiter sind gleichzeitig Verbindungselement und ermöglichen schnelles Anreihen im Auditorium. Bis zu 45 Stühle lassen sich problemlos stapeln.

Hip Appearance. Smart Engineering.

m 210/211. The youthful chair range with the brush sled base. Optionally available with armrests as well as seat and backrest upholstery. The backrest is available in a choice of an en-bloc look or featuring an en-vogue mesh detail. Inconspicuous glides function simultaneously as ganging devices and enable auditorium row seating to be set up quickly. Up to 45 chairs in a stack.



Farben/Colours

	01 Schwarz Black		512 Grün Green
	20 weiss White		516 Dunkelblau Dark blue
	3020 Rot Red		517 Grau Grey



TREND
STYLE
COLLECTION

STRAIGHT
&
ELEGANT

m 225

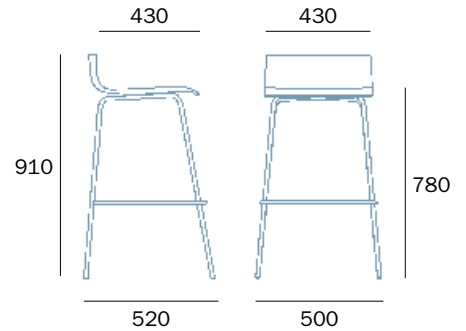

Schlanke Linie. Starke Ausstrahlung.

m 225. Das bewusst schnörkellos schlank gestaltete Barhockerprogramm mit dem gewissen Etwas. Angenehm schlicht im Auftritt. Formal reduziert auf das Wesentliche. Optional mit Vollpolsterung. Repräsentativ in Lounge, Lobby und Foyer. Gesprächsfördernd in kommunikativen Bereichen wie Showrooms und Kundenbistros.

Trim lines. Loads of charisma.





m 225. The intentionally no-frills, slimline range of barstools with that certain "je ne sais quoi". Pleasantly unpretentious in appearance. Reduced to the bare design essentials. Optionally available with full upholstery. Looks elegant in lounges, lobbies and foyers. Facilitates communication in environments such as showrooms and in-house bistros.



Sitzschalen/Seat shells

 **Buche**
klar lackiert
Beech in
neutral varnish
finish

DURO

- | | |
|--|---|
|  U961
Schwarz
Black |  U708
Grau
Grey |
|  U323
Rot
Red |  W980
Weiß
White |
|  U630
Grün
Green | |



TREND
STYLE
COLLECTION



SMART
&
UNIVERSAL

m 525/526/527



Gute Ideen. Viele Möglichkeiten.

m 525/526/527. Das universelle System sorgt mit seinen vielen unterschiedlichen Varianten für Abwechslung im Objekt und lässt dabei stets einen gemeinsamen formalen roten Faden erkennen. Die angenehm geformten Sitzschalen sind aus neunfach verleimtem Buchenholz, die Stuhlgestelle aus Stahlrohr.

Great ideas. Wide range of options.

m 525/526/527. This universally applicable system with its wide range of different versions provides design versatility in any building and yet is characterised by design consistency. The ergonomically shaped seat shells are made of 9-ply adhesive-bonded beech whilst the frames are made of tubular steel.



4-Fußmodelle mit Kunststoff- oder Filzgleitern. Optional Gelenkgleiter mit Edelstahlkappe oder Akustikgleiter mit Schwingungsdämpfer und je nach Bodenbeschaffenheit austauschbaren Gleiteinsätzen.

4-leg frames with synthetic or felt glides. Options – pivot glides with stainless steel caps or low-noise glides with vibration dampeners and replaceable inserts to match the floor.



Alle 4-Fußmodelle optional mit Reihenverbindern für einfaches Anreihen durch Einhängen ineinander.

All 4-leg models are optionally available with clip-in ganging devices for simple and effective row seating.



Gestell „Freischwinger“ optional mit Kantenschutz zum Einhängen in die Tische für leichte Bodenreinigung.

“Cantilever” frame optionally available with protective lipping to enable chairs to be stacked on tables to allow floors to be cleaned.

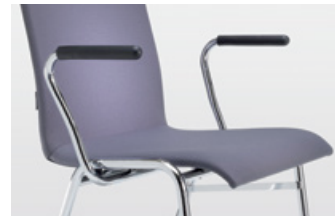

Beim oval gebogenen Stuhlgestell weisen die Armlehnen nach vorne. Die Armauflage ist aus strapazierfähigem Kunststoff.

Oval-curve chair frames feature armrests that face forwards. The armrest pads are made of hard-wearing synthetic material.



Beim rund gebogenen Gestell weisen die Armlehnen nach hinten. Ebenfalls ausgestattet mit Armauflagen aus Kunststoff.

Rounded-curve chair frames feature armrests that face backwards. Also fitted with synthetic armrest pads.

TREND
STYLE
 COLLECTION



FRESH
 &
 FANCY

Gestelle, Sitzschalen, Polster – beliebig kombinierbar!
Frames, seat shells and cushions can be combined as you like!

m 525

Sitzschale/Seat shell

Rücken trapezförmig/Trapezium-shaped backrest



m 526

Sitzschale/Seat shell

Rücken tailliert/Tapered backrest



m 527

Sitzschale/Seat shell

Rücken gerade/Straight backrest



Rückenpolster/Backrest cushion **RP**
 Sitzpolster/Seat cushion **SP**

Gestell/Frame

GO „Oval“ /“Oval“



GR „Rund“ /“Round“



GS „Spinne“ /“Spider“



GF „Freischwinger“ /“Cantilever“



m 525/526/527



Alle Sitzschalen optional mit Designausfräsungen, z. B. mit Griffloch oder freien Mustern.

All seat shells optionally available with design details, e.g. grab handles or perforation patterns.

Transportkarren in verschiedenen Ausführungen.

Range of different trolleys available.



Tolle Kombinationen. Leckere Farben.

m 525/526/527. Die Kombinationsvielfalt sorgt für hohe Anpassungsfähigkeit an Einrichtungsbereiche wie z. B. Büro, Empfang, Wartezone, Besprechung, Seminar, Tagung und Auditorium. Der Variantenreichtum ergibt sich aus 4 Gestellvarianten, 3 Sitzschalentypen und 2 Polsterausführungen sowie einer attraktiven Auswahl unterschiedlicher Sitzschalenfarben.

Great combinations. Attractive colours.

m 525/526/527. The wide range of combinations ensures a high degree of design flexibility in interior spaces, such as offices, reception and waiting areas, meeting and workshop rooms or conference and auditorium facilities. This flexibility is based on 4 frame options, 3 seat shell types and 2 upholstery finishes combined with an attractive choice of different seat shell colours.

Gestell/Frame	Mit Sitzschalen/With seat shells															
	m 525						m 526					m 527				
	A	B	C	D	E	F	B	C	D	E	F	B	C	D	E	F
GO	430	460	434	560	505	850	460	430	550	505	820	440	430	550	505	845
GR	435	460	434	555	508	855	460	430	545	508	815	440	430	545	508	840
GS	425	460	434	535	550	845	460	430	525	550	835	440	430	525	550	860
GF	440	460	434	540	505	870	460	430	550	505	840	440	430	530	505	865

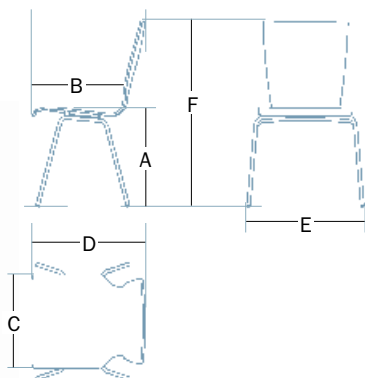

Gestelle/Frames

- glanzverchromt/
bright chromed
- pulverbeschichtet/
powder-coated

 RAL 7016:
Anthrazitgrau
Anthracite
grey

 RAL 9006:
Weißaluminium
brillant/
Brilliant white
aluminium

 RAL 9005:
Tiefschwarz/
Jet black

Sitzschalen/Seat shells

 Buche
klar lackiert
Beech in
neutral varnish
finish

 Buche gebeizt/
Stained beech

 RAL 9005:
Tiefschwarz
Jet black

 RAL 5007:
Brilliantblau
Brilliant blue

 RAL 6000:
Patinagrün
Patina green

 RAL 1012:
Zitronengelb
Lemon yellow

 RAL 3002:
Karmintrot
Crimson red

DURO

 U961
Schwarz
Black

 U323
Rot
Red

 U630
Grün
Green

 U708
Grau
Grey

 W980
Weiß
White



TREND
STYLE
COLLECTION

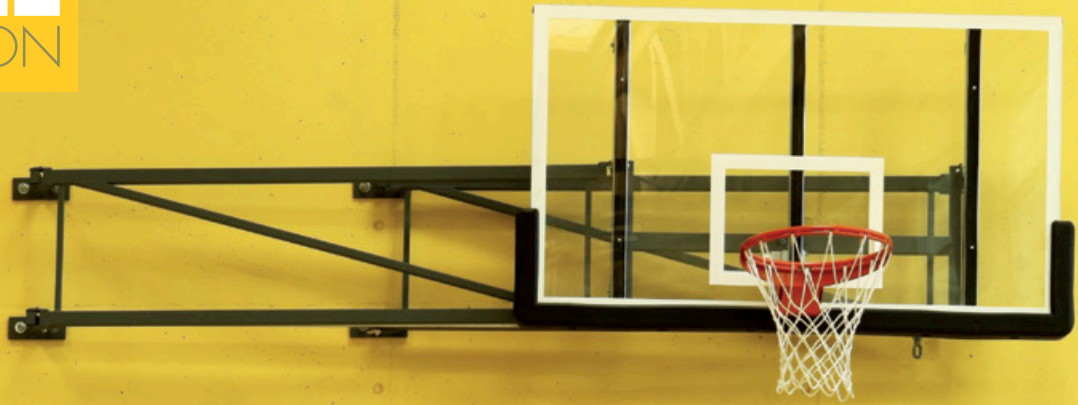

UNIQUE
&
BEAUTIFUL

m 528



Besonderer Charme. Jugendliche Frische.

m 528. Die Herzform steht für Lebenslust, Kreativität und Spaß an den vielen schönen Dingen dieser Welt. Aufbruchstimmung für alle, die mehr Frische in ihr Objekt bringen wollen. Attraktive Holzdekors und freche Farben runden die kreativ progressive Wirkung dieses sehr bequemen Sitzmöbels ab.

Particular charm. Youthful vigour.

m 528. The heart shape represents joie de vivre, creativity and enjoyment of all the wonderful things this world has to offer. A spirit of optimism that infects those people wanting to freshen up their interiors. Attractive wood laminates and bold colours cap off the creatively go-ahead appeal of this very comfortable seating.

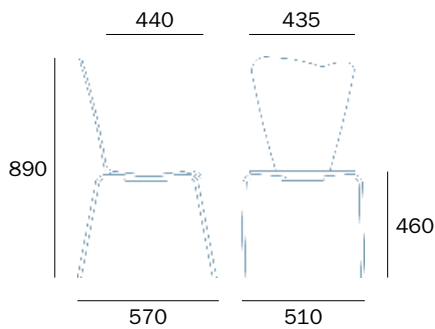

Sitzschalen/Seat shells

 Buche
klar lackiert
Beech in
neutral varnish
finish

DURO

-  U961
Schwarz
Black
-  U323
Rot
Red
-  U630
Grün
Green
-  U708
Grau
Grey
-  W980
Weiß
White



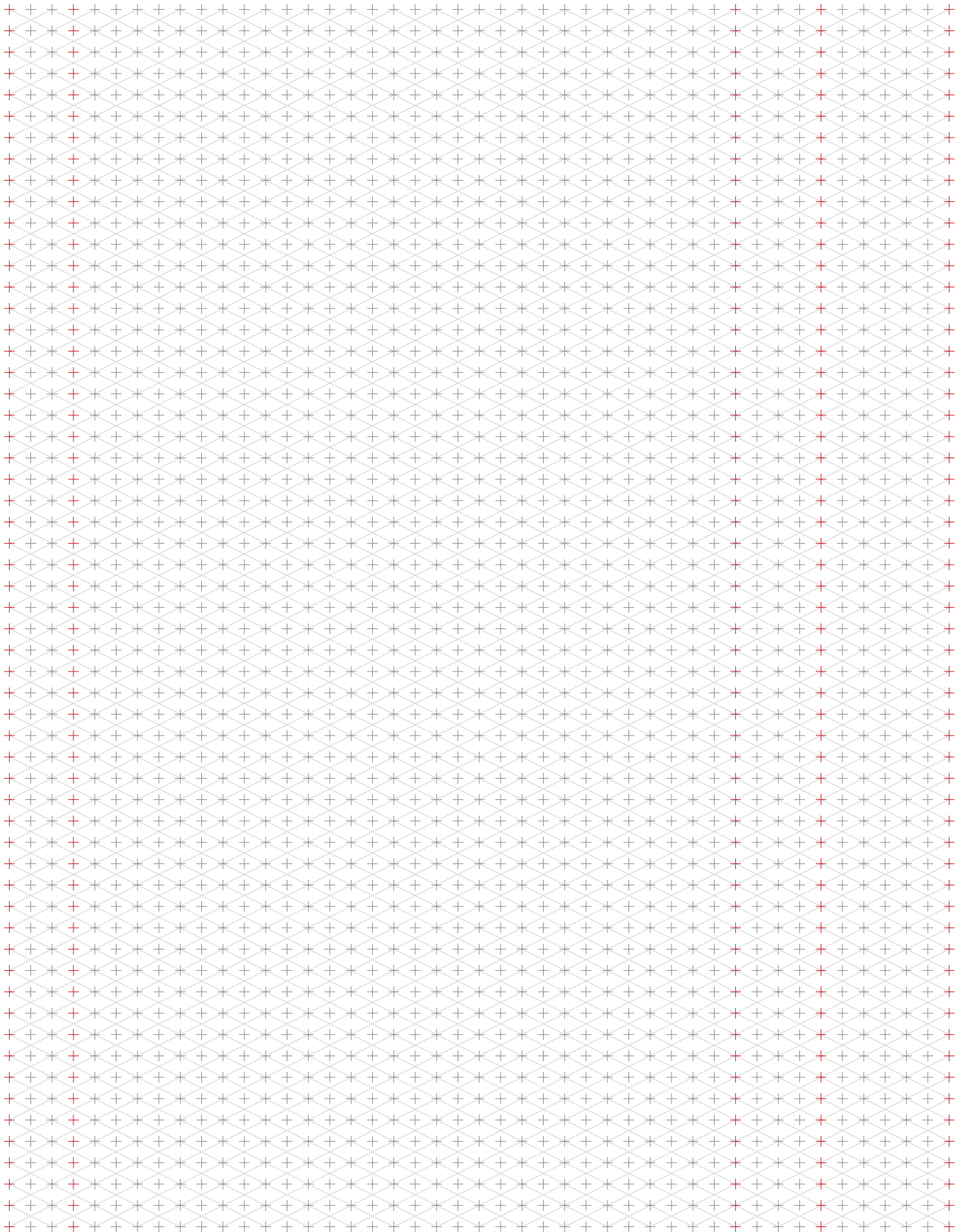

D.T.E. CONCEPT GmbH

Gartenstrasse 115a · CH-4132 Muttenz / BL

Telefon +41 61 811 80 08

Fax +41 61 811 80 09

www.dte-concept.ch

office@dte-concept.ch

